

ccProgrammer User Manual



This document is the copyright of Money Controls Ltd and may not be reproduced in part or in total by any means, electronic or otherwise, without the written permission of Money Controls Ltd. Money Controls Ltd does not accept liability for any errors or omissions contained within this document. Money Controls Ltd shall not incur any penalties arising out of the adherence to, interpretation of, or reliance on, this standard. Money Controls Ltd will provide full support for this product when used as described within this document. Use in applications not covered or outside the scope of this document may not be supported. Money Controls Ltd. reserves the right to amend, improve or change the product referred to within this document or the document itself at any time.

Contents

1. Diary of Changes	4
2. Introduction	4
3. ccProgrammer Contents	6
4. Installation	7
4.1 ccProgrammer connections	7
4.2 ccProgrammer software installation.....	8
5. Running ccProgrammer	9
6. Bus scan	10
6.1 Single Product	10
6.2 Multiple Products	11
6.21 CcProgrammer Multi Drop Expander.....	11
6.3 Multi-Scan.....	12
7. ccProgrammer Menu's	13
7.1 ccP_32Bit	13
7.11 ccP_32Bit - Print a page of SR3 Labels.....	13
7.12 ccP_32Bit - Print a page of SR5 Labels.....	13
7.13 ccP_32Bit - Print Preview	13
7.13,1 <i>Print Preview Screen</i>	14
7.14 ccP_32Bit - Print.....	14
7.15 ccP_32Bit - Refresh.....	15
7.16 ccP_32Bit - Printer Font.....	15
7.16,1 <i>Printer Font Screen</i>	15
7.17 ccP_32Bit - Exit	15
7.2 Diagnostics.....	16
7.21 Diagnostics - General Diagnostics.....	16
7.21,1 <i>General Diagnostics Screen</i>	16
7.22 Diagnostics - Coin Identification.....	17
7.22,1 <i>Most Likely Coin Spec</i>	17
7.22,2 <i>Global Comparison</i>	17
7.23 Diagnostics - Create Diagnostics Report	18
7.3 Programming.....	18
7.31 Programming - Coins.....	18
7.32 Programming - Settings.....	18
7.32,1 <i>Settings Screen</i>	19
7.33 Programming - Teach.....	20
7.33,1 <i>Teach Method</i>	20
7.34 Programming - Tweak	22
7.34,1 <i>Tweak Display</i>	22
7.34,2 <i>Tweak Disabled</i>	23
7.35 Programming - Flags	23
7.35,1 <i>Programming - Flags SR5</i>	23
7.35,2 <i>Programming - Flags BDTA</i>	24
7.35,3 <i>Programming - Flags SR3</i>	25
7.35,4 <i>Programming - Flags Condor Plus</i>	26
7.36 Programming – Sorter	27
7.37 Programming – Inhibit Register	28
7.38 Programming – Totaliser	29
7.4 Coin Handling	30
7.41 Coin Handling – Accept	30
7.42 Coin Handling – Reject.....	30
7.43 Coin Handling – Error	31
7.44 Coin Handling – SR3 / Condor Plus.....	31
7.5 Macros.....	32
7.51 Macros - Install	32
7.52 Macros - Delete	32
7.53 Macros - Run	32
7.6 Options	33
7.61 Options - Change Password.....	33
7.62 Options – Scan	33
7.63 Options - Recharge.....	33
7.64 Options - Restore Addresses.....	33
7.7 Configuration	34

- 7.8 Coin Spec Install..... 34
- 7.81 Coin Spec Install – ccProgrammer 34
- 7.9 About 34
- 8. Programming Coins 35**
- 8.1 Programming Coins - SR5..... 35
- Changing the Coins - SR5 36
- 8.12 Programming Options - SR5..... 37
- 8.12.1 Credit Programming Option - SR5..... 37
- 8.13 Credit Code Modes - SR5..... 37
- 8.14 Routing - SR5 38
- 8.15 Mode..... 38
- 8.16 Order - SR5 38
- 8.17 Coin Specification - SR5..... 38
- 8.18 Validator - SR5 39
- 8.19 Coinspec Version - SR5 39
- 8.2 Programming Coins - SR3..... 40
- 8.21 Changing the Coins - SR3..... 41
- 8.22 Programming Options - SR3..... 42
- 8.23 Credit Code Modes - SR3..... 42
- 8.24 Order - SR3 43
- 8.25 Coin Specification - SR3..... 43
- 8.26 Validator - SR3 43
- Coinspec Version - SR3 43
- 8.3 Programming Coins - Condor Plus 44
- 8.31 Changing the Coins - Condor Plus 45
- 8.32 Programming Options - Condor Plus 46
- 8.33 Credit Code Modes - Condor Plus 46
- 8.34 Order - Condor Plus..... 47
- 8.35 Coin Specification - Condor Plus 47
- 8.36 Validator - Condor Plus..... 47
- Coinspec Version - Condor Plus..... 47

Figures

- Figure 1: **ccProgrammer** layout..... 5
- Figure 2: **ccProgrammer** 5 inch acceptor cable 6
- Figure 3: **ccProgrammer** 3 inch acceptor cable 6
- Figure 4: **ccProgrammer** serial comms cable..... 6
- Figure 5: **ccProgrammer** connections (e.g. SR3)..... 7
- Figure 6: **ccProgrammer** multi-drop expander 11
- Figure 7: **ccProgrammer** main screen (SR5 mode 1) 13

1. Diary of Changes

Issue 3.0.....	March 2002
➤ 1 st Issue for version 3.5	
Issue 3.1.....	6 th Sept 2002
➤ Modification to disclaimer.	
Issue 3.2.....	7 th Aug 2003
➤ Applied TMWP V3.2	
➤ Changed ccTalk [®] to ccTalk throughout the document.	
Issue 3.3.....	30 th June 2004
➤ Changed footer	

2. Introduction

ccProgrammer has been developed to enable users to re-program the following products:-

- SR5
- SR5R
- SR3
- Condor Plus
- C435S

ccProgrammer will re-program the SR range of acceptors without the need to enter any coins. Condor Plus and C435S will still need to have coins entered for readings to be taken in order to re-program.

Figure 1: ccProgrammer layout

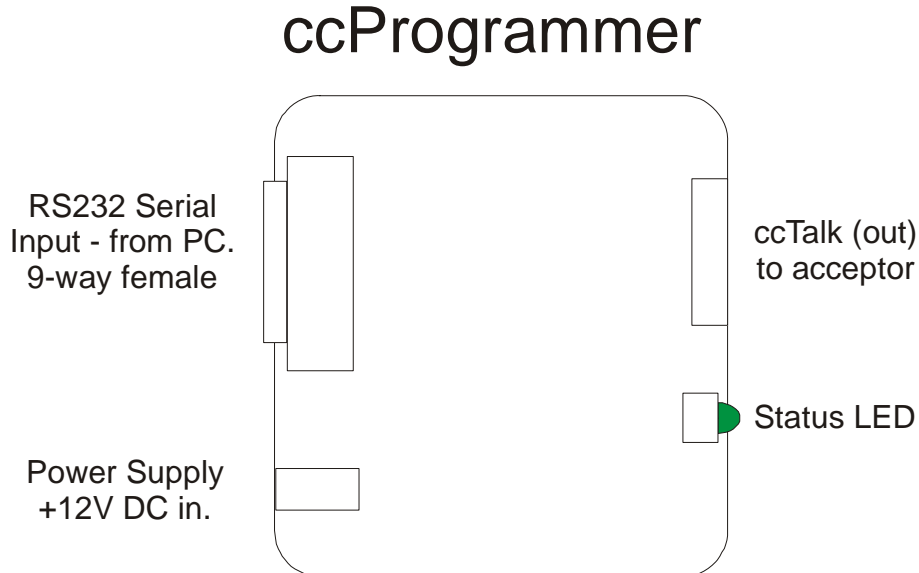

3. ccProgrammer Contents

The **ccProgrammer** kit consists of the following items:-

- 1 x **ccProgrammer** case.
- 1 x Installation CD.
- 1 x Coinspec CD.
- 1 x **ccProgrammer** pod. (see [Figure 1](#)).
- 1 x SR5 / C435S cable. (see [Figure 2](#)).
- 1 x SR3 / Condor Plus cable. (see [Figure 3](#)).
- 1 x 9 pin 'D' type cable - female to female. (see [Figure 4](#)).
- 1 x Power cables (red and black).

Figure 2: ccProgrammer 5 inch acceptor cable

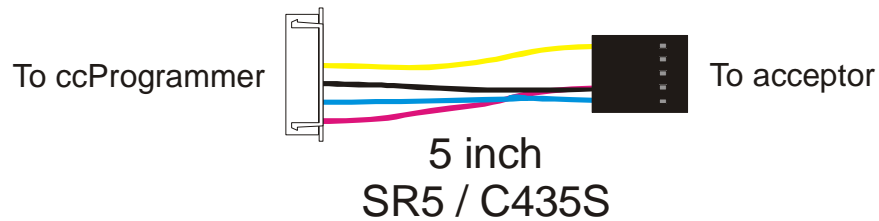

Figure 3: ccProgrammer 3 inch acceptor cable

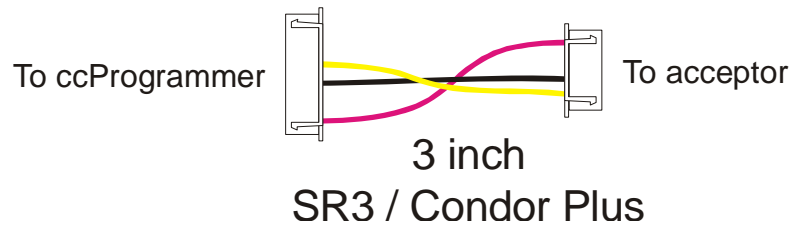
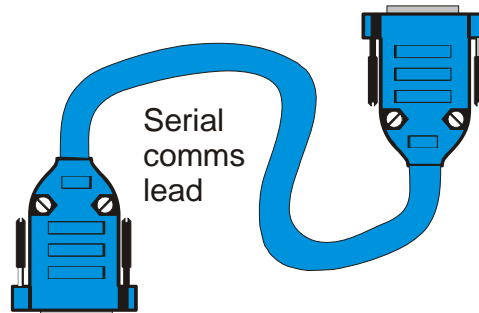

Figure 4: ccProgrammer serial comms cable



4. Installation

4.1 ccProgrammer connections

Refer to [Figure 5](#).

1. Connect one end of the 9 way 'D' type connector to a free serial port on the computer.
2. Connect the **ccProgrammer** pod to the other end of the cable.
3. Connect the red and black power cables to a 12V 1A (min) power supply. (preferably a 3A power supply should be used).
4. Connect the DC connector to the **ccProgrammer** pod.
5. Connect a product cable, 3 inch or 5 inch, from the **ccProgrammer** pod to the relevant product.
6. Switch on the power supply and ensure the **GREEN** LED, on the **ccProgrammer** pod is ON and the **GREEN** LED on the product is also ON.

Figure 5: ccProgrammer connections (e.g. SR3)

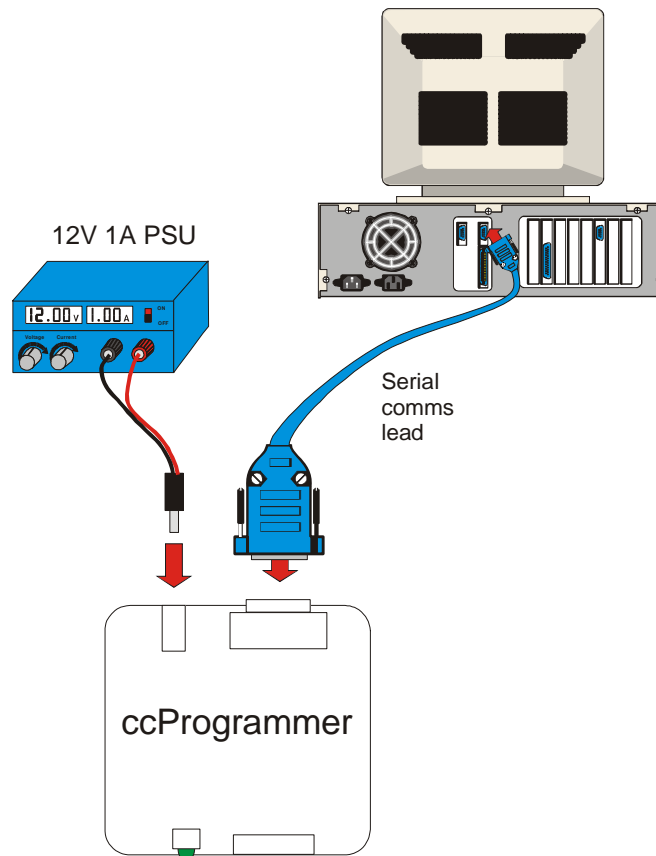

4.2 ccProgrammer software installation

Place the **ccProgrammer_32** CD into your CD ROM drive. In START/RUN type **D:\setup.exe** (substituting your CD drive letter for D:\) and installation of the **ccProgrammer** will commence.

Alternatively, the software will auto run if this feature has been enabled on the PC. The following on-screen instructions will be seen.

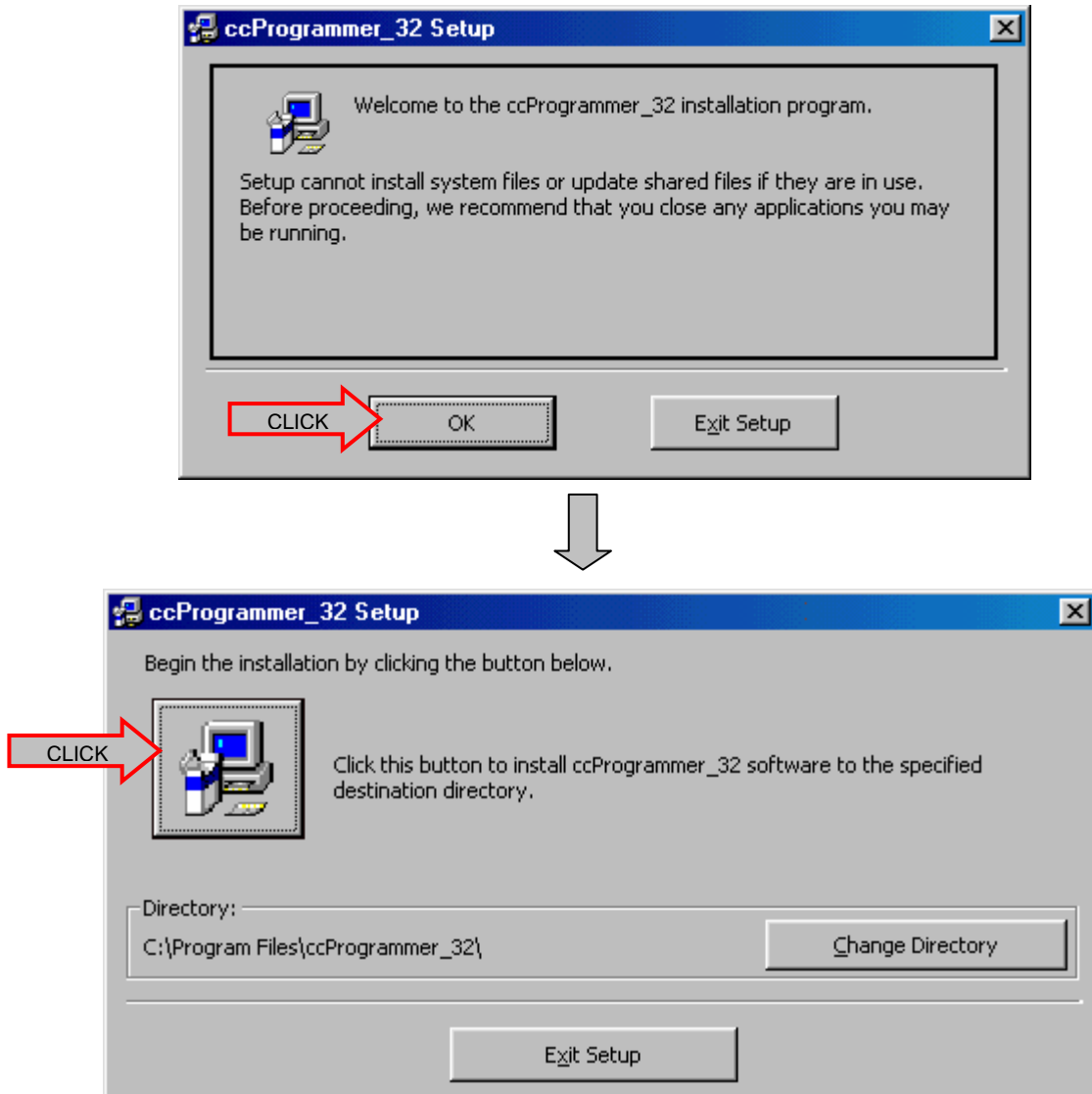

Choose the directory that you wish to install the **ccProgrammer** into and then click on the computer icon. **ccProgrammer** will now be installed into the selected directory.

5. Running ccProgrammer

Start **ccProgrammer** by selecting the “**ccProgrammer**” item from the <START>, <PROGRAMS> menu.

After a short delay the following screen should appear.

Note: The following screen shots may vary from actual ones.

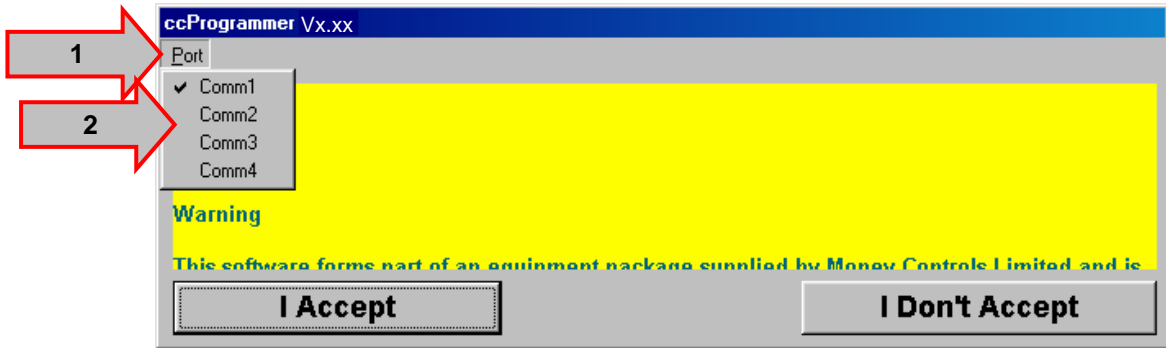

If this is the 1st time the **ccProgrammer** software has been run, then click on [**Port**] ⇒ 1 and ensure that the correct Comm port has been selected ⇒ 2.

If **ccProgrammer** has been run before click [**I Accept**].

If you are not the authorised user then click [I Don't Accept**].**

After acknowledging a message about attaching the **ccProgrammer**, and assuming that the **ccProgrammer** is working correctly, the following password screen is shown. If there is an error, an appropriate error message will be displayed.

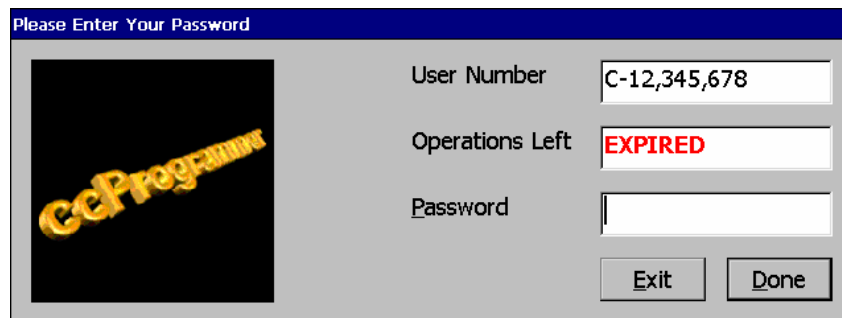

The very first time the program is run, you will need to obtain a recharge code from Money Controls Technical Services Department. This is why the above screen shot displays “EXPIRED”. Otherwise, your licence period or operations left count will be shown. At this point, please make a note of your user number, as you may need to quote this to us in the future:

Please enter your user number in the box below

User number:-

Enter the password in the [**Password**] box. By default the password is **ccProgrammer**.

Note:- The password is NOT case sensitive.

6. Bus scan

6.1 Single Product

When only one product is on the **ccTalk** bus make sure that the **[Quick]** checkbox is checked ⇒ 3. This is the quickest scan method as only one address is scanned and only one baud rate is used.

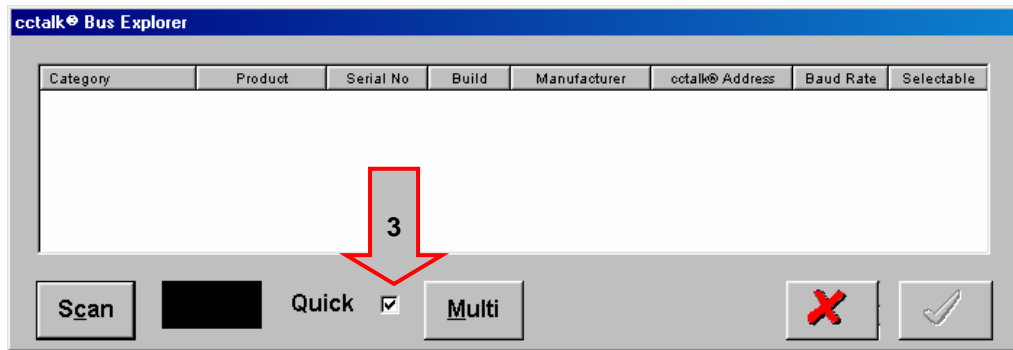

Click the **[Scan]** button to start **ccProgrammer**.
ccProgrammer will now read the **ccTalk** bus for address 2 at a baud rate of 9600.

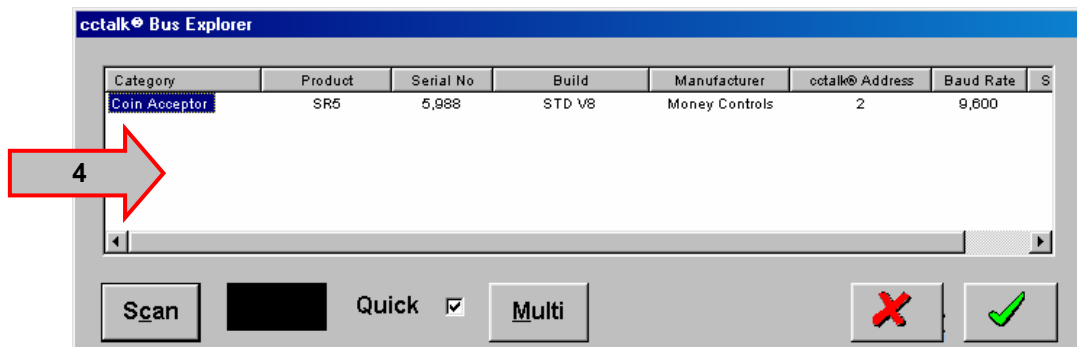

When a product is found, its information is displayed in the window as above ⇒ 4.
Click the **GREEN** tick to continue.
Click the **RED** cross to exit.

Tip:- After entering the password, you can proceed through the screens simply by pressing the <ENTER> key.

6.2 Multiple Products

ccTalk allows the user to connect more than one product to the **ccTalk** bus or even more than one type of product (coin acceptor / coin hopper (**not supported by ccProgrammer**)/ note acceptor etc).

Using a Multi Drop Expander, more than one product, of the same type, can be programmed at the same time.

Note:- For multiple programming, only ONE product type should be used, e.g. SR5 Top Entry.

6.21 CCPROGRAMMER MULTI DROP EXPANDER

The multi drop expander allows up to 8 of the **same** product to be connected to **ccProgrammer** simultaneously.

The expander is connected to the **ccProgrammer** in the same way a product would be. The products are then individually connected to the expander.

Notes:- although 8 products can be connected at the same time, they are still programmed individually. Therefore actual time saving is minimal.

ALL the products will be programmed to the same specification.

Any number of products between 1 and 8 can be connected.

Figure 6: **ccProgrammer** multi-drop expander

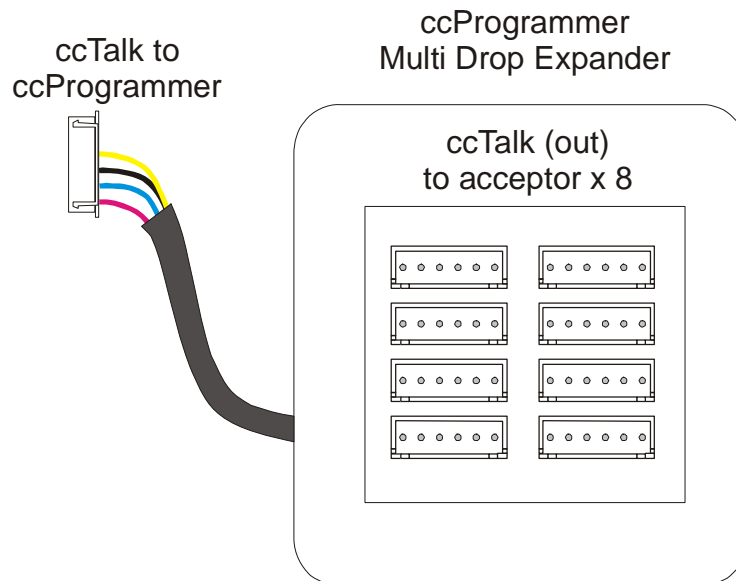

6.3 Multi-Scan

When all the products are connected, de-select **[Quick]** ⇒ 5 and click **[Multi]**.
The indicator ⇒ 6 will initially turn **RED** followed shortly by flashing **GREEN**.
Information received about the attached products will be shown in the window ⇒ 7.

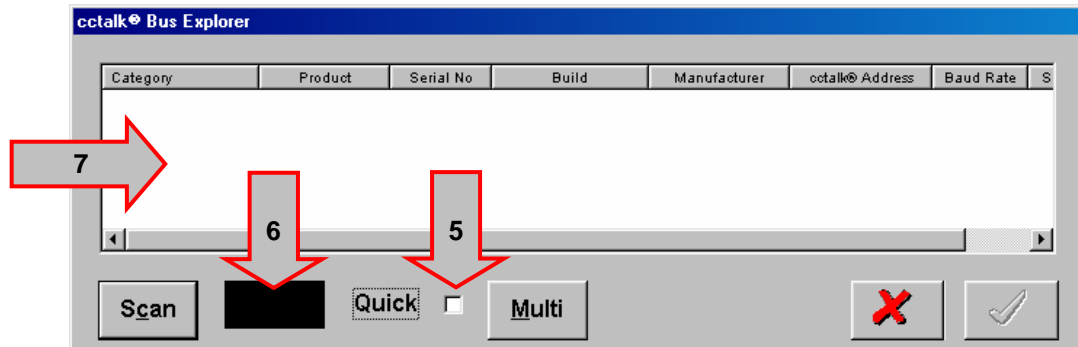

When **ccProgrammer** performs a Multi scan, each products address is temporarily changed so that there are no communication conflicts.
Because of this a Warning message is displayed.

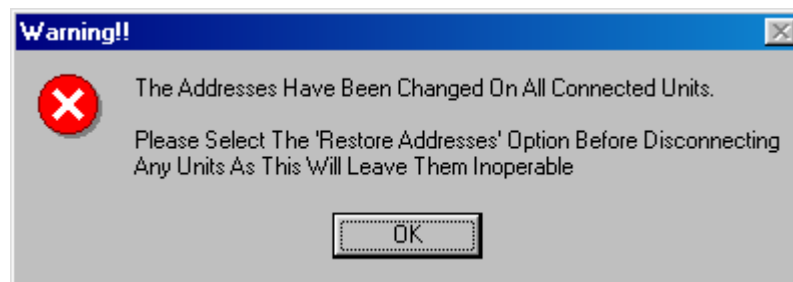

Below is a single product which has been scanned using **[Multi]**. Note that the address is now 15. To continue click the **GREEN** tick. To exit, click the **RED** cross.
If there is more than one acceptor connected, programming later will program ALL the acceptors the same.

Note: If you need to view 1 product in particular, highlight the product required, and then click the GREEN tick. The details shown in the following screens will then relate to the highlighted acceptor only.

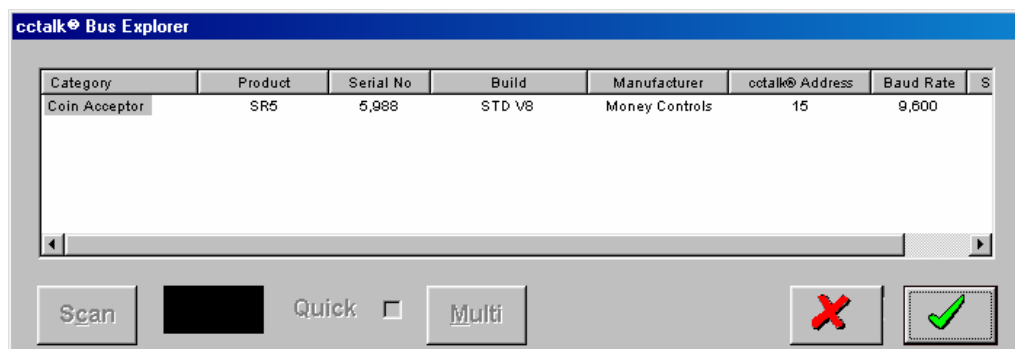

7. ccProgrammer Menu's

Figure 7: ccProgrammer main screen (SR5 mode 1)

Channel	COINS	Sorter Routes	Parallel Credit Code	Binary Credit Code	Serial Credit Code
1	EU-200	4\A 4\A 4\A 4\A	000001	01000	1
2	EU-100	4\A 4\A 4\A 4\A	000010	01001	2
3	EU-050	4\A 4\A 4\A 4\A	000100	01010	3
4	EU-020	4\A 4\A 4\A 4\A	001000	01011	4
5	EU-010	4\A 4\A 4\A 4\A	010000	01100	5
6	EU-005	4\A 4\A 4\A 4\A	000001	01101	6
7	EU-002	4\A 4\A 4\A 4\A	000010	01110	7
8	EU-001	4\A 4\A 4\A 4\A	000100	01111	8
9	4\A 4\A 4\A 4\A	000001	11000	9
10	4\A 4\A 4\A 4\A	000010	11001	10
11	4\A 4\A 4\A 4\A	000100	11010	11
12	4\A 4\A 4\A 4\A	001000	11011	12
13	4\A 4\A 4\A 4\A	010000	11100	13
14	4\A 4\A 4\A 4\A	000001	11101	14
15	4\A 4\A 4\A 4\A	000010	11110	15
16	4\A 4\A 4\A 4\A	000100	11111	16

The coins description consists of the country code followed by the value. If the value is 1,000 then this is displayed as 1K0, 10,000 is displayed as 10K.

The Sorter Routes, Parallel and Binary Credit Codes are those which are currently programmed. **Different products will show different information on this screen.**

Note:- Serial Credit Codes are NOT editable.

7.1 ccP_32Bit

7.11 CCP_32BIT - PRINT A PAGE OF SR3 LABELS

Not currently available.

7.12 CCP_32BIT - PRINT A PAGE OF SR5 LABELS

Not currently available.

7.13 CCP_32BIT - PRINT PREVIEW

Print preview shows the current screen details (see Figure 7) in a text format, on the screen. This is a method of keeping a record of the coins programmed and their positions, the sorter paths and credit codes.

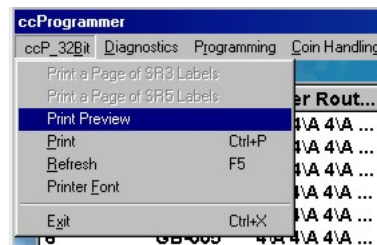

7.13,1 Print Preview Screen

The screenshot shows a window titled "Print Preview" with a table of coin details. Below the table, it displays product information and the print date.

Channel	COINS	Sorter Routes	Parallel Credit	Binary Credit C	Serial Credit
1	EU-200	4\A 4\A 4\A 4\A	000001	01000	1
2	EU-100	4\A 4\A 4\A 4\A	000010	01001	2
3	EU-050	4\A 4\A 4\A 4\A	000100	01010	3
4	EU-020	4\A 4\A 4\A 4\A	001000	01011	4
5	EU-010	4\A 4\A 4\A 4\A	010000	01100	5
6	EU-005	4\A 4\A 4\A 4\A	000001	01101	6
7	EU-002	4\A 4\A 4\A 4\A	000010	01110	7
8	EU-001	4\A 4\A 4\A 4\A	000100	01111	8
9	4\A 4\A 4\A 4\A	000001	11000	9
10	4\A 4\A 4\A 4\A	000010	11001	10
11	4\A 4\A 4\A 4\A	000100	11010	11
12	4\A 4\A 4\A 4\A	001000	11011	12
13	4\A 4\A 4\A 4\A	010000	11100	13
14	4\A 4\A 4\A 4\A	000001	11101	14
15	4\A 4\A 4\A 4\A	000010	11110	15
16	4\A 4\A 4\A 4\A	000100	11111	16

Product SR5, build STD8, S/N 5,988, ROM ID SR5-V1.30
 Printed From ccProgrammer V3.5.65 on 06/03/02 at 20:41:01

As well as the coin details, the screen also shows the product type, build, ROM version, the **ccProgrammer** version and the date on which the print was made.

Note : The date shown is the same as the PC clock. Make sure the PC clock is set correctly.

7.14 CCP_32BIT - PRINT

This prints the main screen information to the Windows default printer.

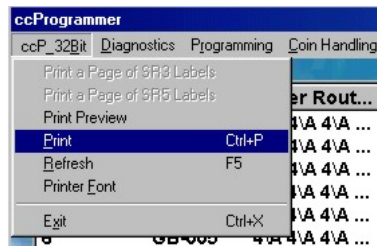

7.15 CCP_32BIT - REFRESH

Re-reads the coin acceptor information and displays it on the screen (see Figure 7).



7.16 CCP_32BIT - PRINTER FONT

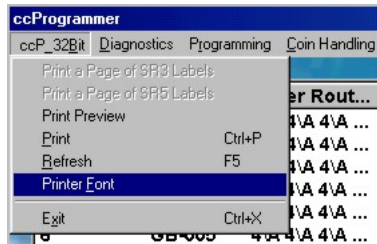

7.16,1 Printer Font Screen

This allows the font style for printing to be changed.

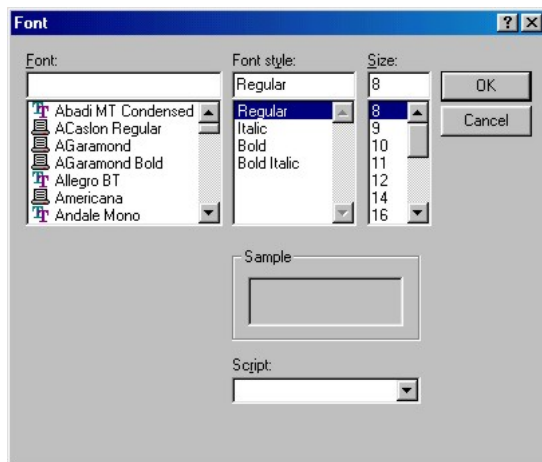

7.17 CCP_32BIT - EXIT

Select **[Exit]** to close ccProgrammer.



7.2 Diagnostics

7.21 DIAGNOSTICS - GENERAL DIAGNOSTICS

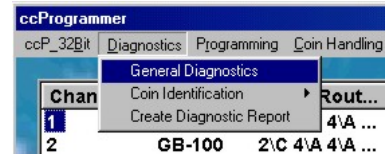

7.21,1 General Diagnostics Screen

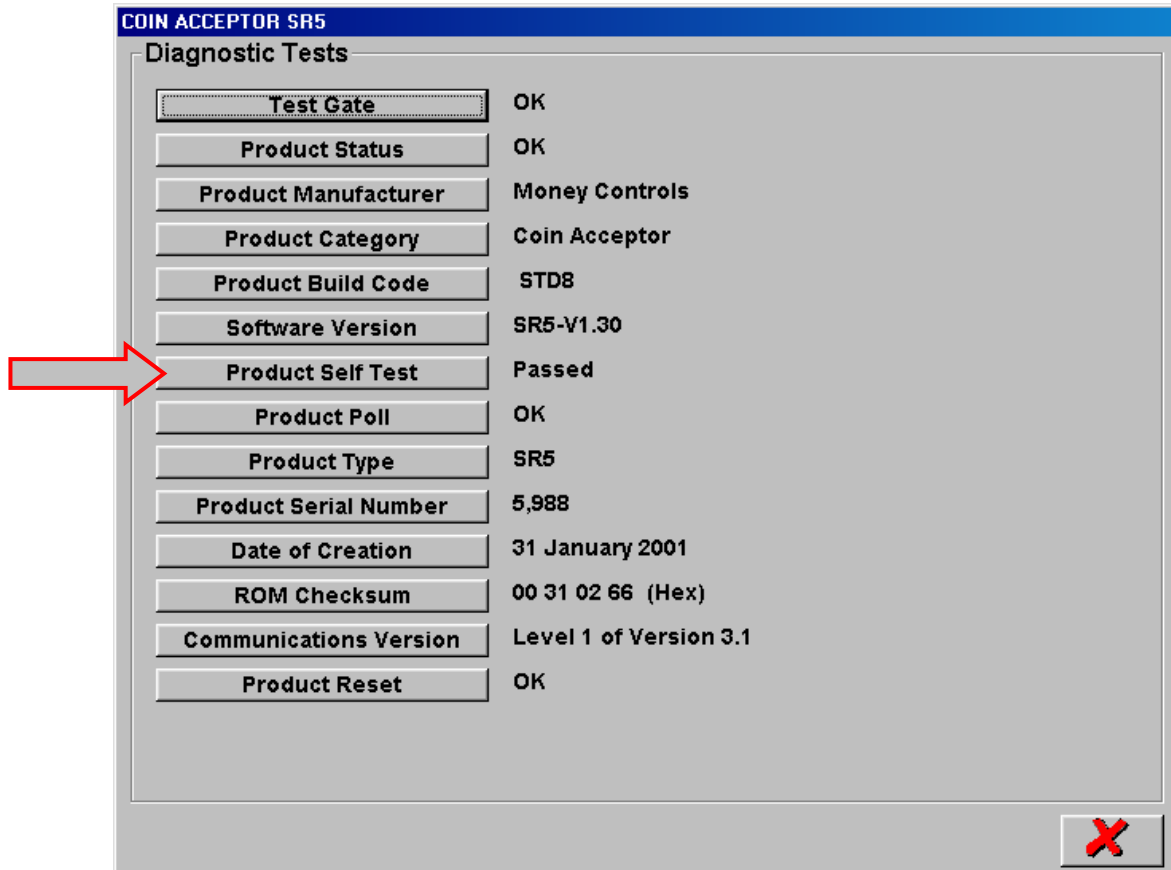

The first time [General Diagnostics] is selected all of the above tests are performed. If you need to repeat any of the above tests simply click on the relevant button again.

Note:- The [Test Gate] test does not guarantee that the accept gate has worked. If you are unsure if the accept gate has opened, click the [Test Gate] button again and listen for the gate opening and closing.

If there is a fault, then [Product Self Test] will give a description as to what the fault is.

7.22 DIAGNOSTICS - COIN IDENTIFICATION

7.22,1 Most Likely Coin Spec.

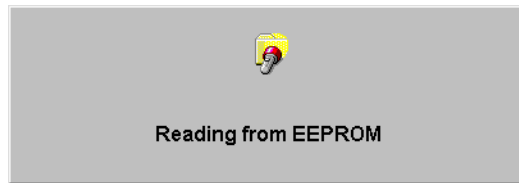
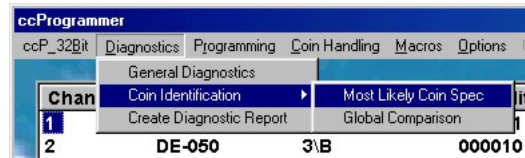

Wind...	Coin Type	Coin Spec 1	Coin Spec2	Coin Spe
1	EU00200A	BEDEEUFRIssue1	EUSEIssue2	EUNLISS
2	EU00100A	BEDEEUFRIssue1	EUSEIssue2	EUNLISS
3	EU00050A	BEDEEUFRIssue1	EUSEIssue2	EUNLISS
4	EU00020A	BEDEEUFRIssue1	EUSEIssue2	EUNLISS
5	EU00010A	BEDEEUFRIssue1	EUSEIssue2	EUNLISS
6	EU00005A	EUSEIssue2	EUNLISS3	EUFRISS
7	EU00002A	EUSEIssue2	EUNLISS3	EUFRISS
8	EU00001A	EUSEIssue2	EUNLISS3	EUFRISS
9	-			
10	-			
11	-			
12	-			
13	-			
14	-			
15	-			
16	-			

Most Likely Match
 Global Comparison

14

Most likely Coin Spec reads the windows and coin id's from the acceptor and then displays which coinspec was most likely used to program the acceptor with. This can then be compared to the latest country coinspec to see if re-programming is required.

7.22,2 Global Comparison

Selecting Global Comparison from the main menu is the same as selecting the Global Comparison check box above ⇒ 14.

Global Comparison compares the coinspec to all other countries.

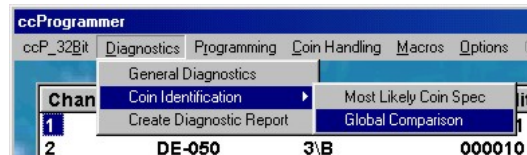

7.23 DIAGNOSTICS - CREATE DIAGNOSTICS REPORT

The Create Diagnostic Report is a new feature.

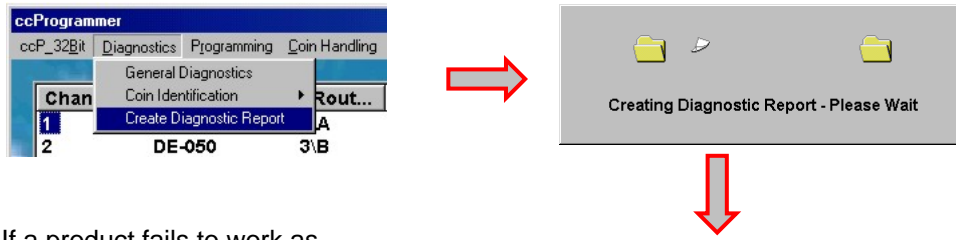

If a product fails to work as expected then use this facility.

The location of the file and the filename is shown in the message box.

e-mail the file to the address shown. Money Controls can then analyse the file contents and diagnose the problem.

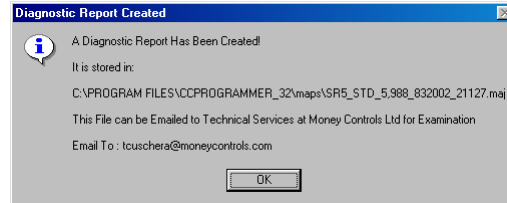

7.3 Programming

7.31 PROGRAMMING - COINS

This is discussed in greater detail in section 8 - Programming Coins.

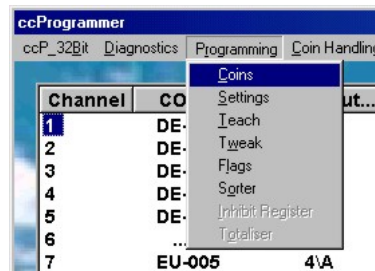

7.32 PROGRAMMING - SETTINGS

Depending on the access level assigned to the **ccProgrammer** [**Settings**] may not be enabled.

The amount of information shown by [**Settings**], if enabled, may vary depending on product and access level.

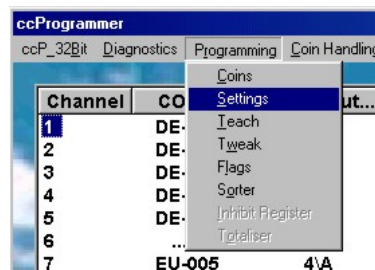

7.32,1 Settings Screen

The amount of information available here to modify will depend on the security level of the **ccProgrammer** being used.

These levels may change from time to time as Money Controls see fit.

For settings which are selectable by all users see section [7.35 Programming - Flags](#).

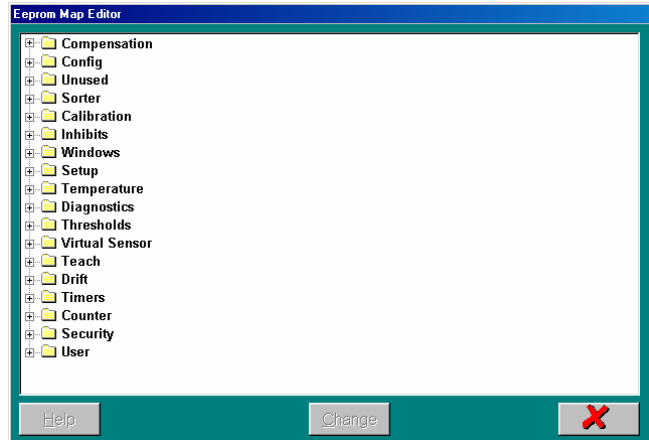

If for any reason a setting needs changing which is locked to the user, Money Controls are able to issue Macro's. See section [7.5 Macros](#) for further details.

Not all the settings are editable and are therefore only for viewing purposes. Some settings are editable in a more user friendly way in the relevant drop down menu.

To edit a setting simply click on the plus sign, this will open up further sub folders. Highlight the setting to be changed, initially this will show the current setting, and click on the **[Change]** button or press the Right mouse button. Enter new data and click the **GREEN** tick.

Note: Changes are written immediately to the acceptor.

*Help is available on some settings. To view the help, click the **[Help]** button.

Click on the **RED** cross to exit the screen.

7.33 PROGRAMMING - TEACH

Although Teach is available using MechTool™ Teach can also be performed using ccProgrammer. There is no difference in the windows programmed between the two Teach methods. i.e. both methods give the same window accuracy.

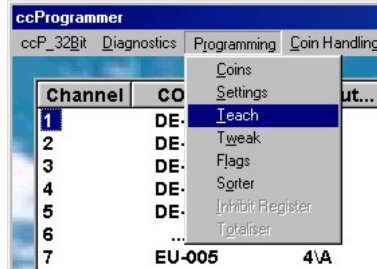

If Teach has been disabled then an error message will be displayed.



To turn Teach ON please refer to section [7.35 Programming - Flags](#)

7.33,1 Teach Method

Select the window to be programmed using the up and down arrows ⇒ 8.

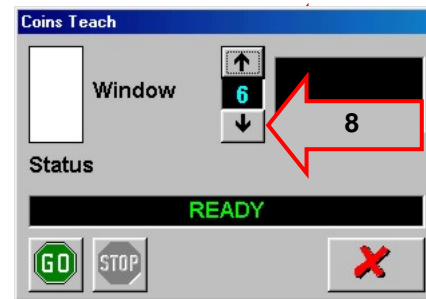

Click on the [GO] button.

Start entering coins. The counter ⇒ 9 will increment after each coin is entered.

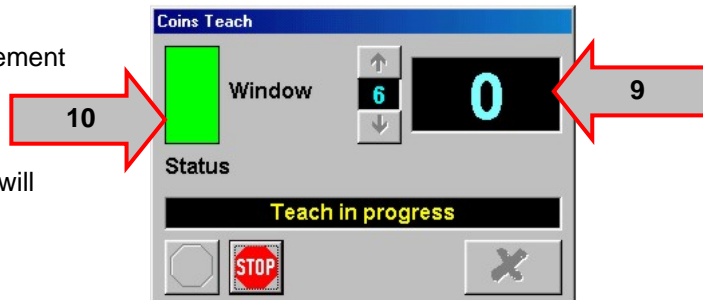

The status window ⇒ 10 will flash GREEN.

8 coins is all that should be required. If more than 8 coins need to be inserted then the quality of coins being taught is poor. Either re-select the programming coins or only use 1 coin.

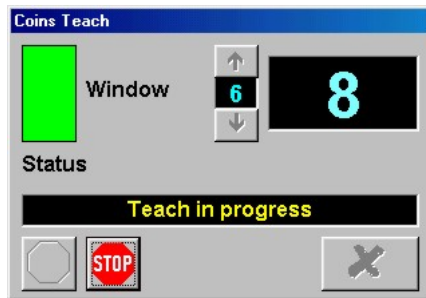

Teach Continued

When completed the message box will change from “**Teach in progress**” to “**Teach complete**”.

Another coin can now be taught.

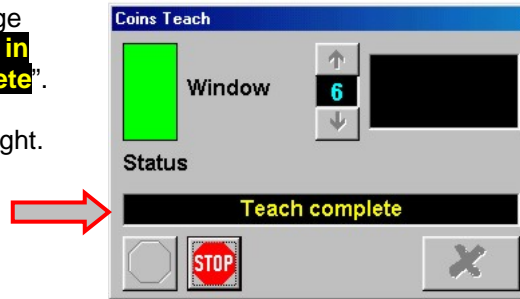

You can click [**STOP**] at any time to abort the Teach process. The message box will change to “**Teach aborted**”
No changes will be made to the coin windows.

“**Teach aborted**” will also be displayed should an error occur during programming.

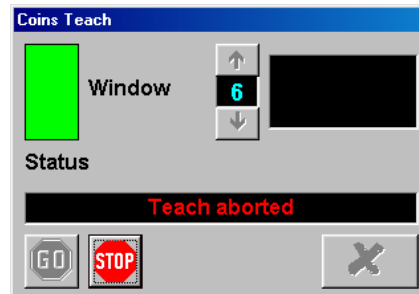

Once completed the main screen will show **TEACH**
In the programmed window.

The screenshot shows a table with the following data:

Channel	COINS	Sorter Rout...	Parallel Credit C...
1	DE-010	4\A	000001
2	DE-050	3\B	000010
3	DE-100	2\C	000100
4	DE-200	3\B	001000
5	DE-500	1\D	010000
6	TEACH	5\A	100000
7	EU-005	4\A	000001

A red arrow points to the 'TEACH' entry in row 6.

7.34 PROGRAMMING - TWEAK

Tweak allows you to change the programmed windows by a set amount.

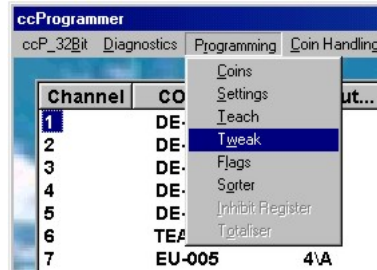

7.34.1 Tweak Display

Each coin position is shown 1 to 16. Adjustments can be made to any of the coin positions.

Sliding the scales to the **left** **reduces** the coin windows by the amount shown. (**Increase Fraud Rejection**).

Sliding the scales to the **right** **increases** the coin windows by the amount shown. (**Increase true coin acceptance**).

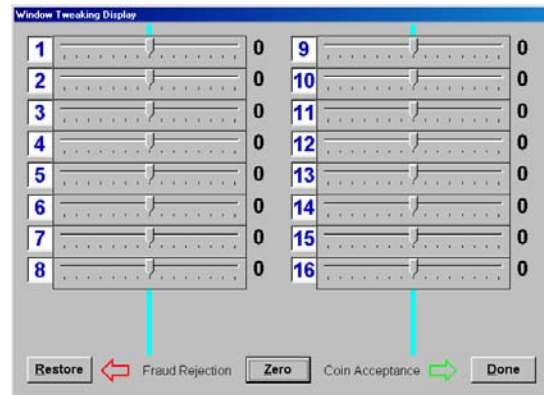

In the example shown:-
Coin 2 has ALL its sensor windows reduced by **-3** counts top and bottom.

Coin 4 has ALL its sensor windows increased by **3** counts top and bottom.

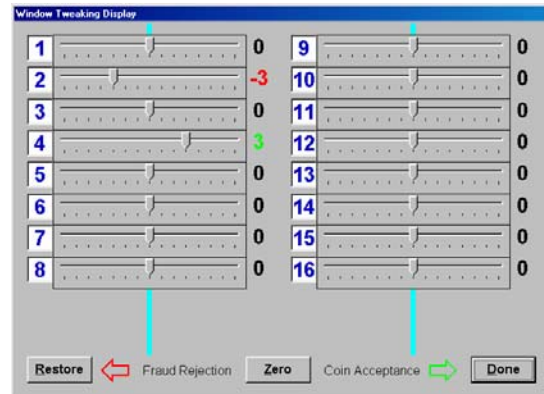

Each coin position consists of 13 sensor windows. Reducing or increasing the 'Tweak' value has the same effect on ALL 13 sensor windows.

To reset ALL the coin positions to zero, click the **[Zero]** button.

If changes are made before clicking **[Done]**, **[Restore]** resets the tweaks to the previously programmed values.

[Done] programmes the tweaks into memory.

If an acceptor only has 12 coin positions then only 12 will be shown.

Note: The exception to this is the SR5 BDTA. Mode 5. Ignore coins 7, 8, 15 and 16 and substitute coins 9 to 14 (shown) with coins 7 to 12 (actual).

SR5 BDTA Mode 9 is correct.

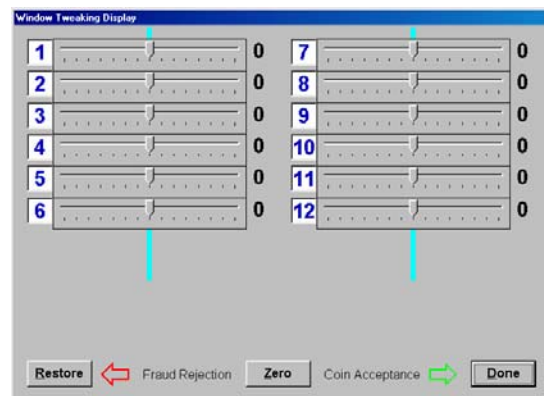

7.34,2 Tweak Disabled

If the Windows Tweak flag is set to OFF, the following message will be shown.



To turn Window Tweaks ON refer to section 7.35 Programming - Flags

7.35 PROGRAMMING - FLAGS

7.35,1 Programming - Flags SR5

Alarms Enabled:

Check = ON
Uncheck = OFF

Sorter Fitted:

Check = ON
Uncheck = OFF

Sorter Timeout ON:

Check = ON
Uncheck = OFF

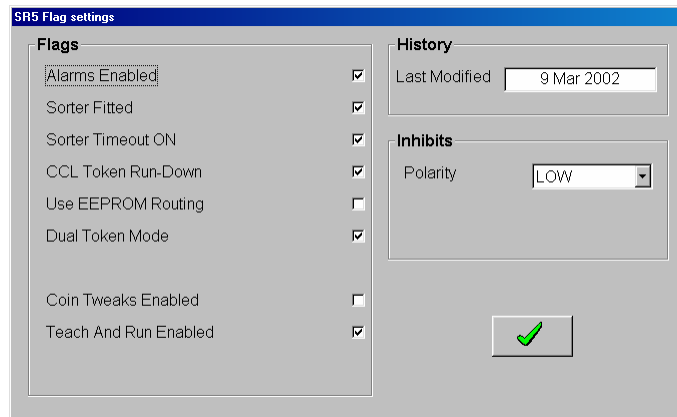

CCL Token Rundown:

Check = ON – coin 5 is a coin.
Uncheck = OFF (Industry STD mode) – coin 5 is from a token group.

Use EEPROM Routing:

Check = ON
Uncheck = OFF (Routing Plug Mode).

Dual Token Mode:

Check = ON (if both banks are prog'd and the token is required in bank 2 – coin 13)
Uncheck = OFF (coin 13 is a coin)

Coin Tweaks Enabled:

Check = ON (see section [7.34 Programming - Tweak](#) for more details)
Uncheck = OFF

Teach and Run Enabled:

Check = ON (see section [7.33 Programming - Teach](#) for more details)
Uncheck = OFF

Note: Teach and Run™ is NOT available if MechTool™ is OFF.

Inhibits – Polarity:

DO NOT CHANGE:

Click on the **GREEN** tick to program the changes into the acceptor.

7.35,2 Programming - Flags BDTA

Alarms Enabled:

Check = ON
Uncheck = OFF

Sorter Fitted:

Check = ON
Uncheck = OFF

Sorter Timeout ON:

Check = ON
Uncheck = OFF

MechTool™ Enabled:

Check = ON (see corresponding tech manual for more details).
Uncheck = OFF (**Teach and Run™** not available)

Coin Tweaks Enabled:

Check = ON (see section [7.34 Programming - Tweak](#) for more details)
Uncheck = OFF

Teach and Run Enabled:

Check = ON (see section [7.33 Programming - Teach](#) for more details)
Uncheck = OFF

Note: Teach and Run™ is NOT available if MechTool™ is OFF.

Inhibits – Polarity:

DO NOT CHANGE:

Click on the **GREEN** tick to program the changes into the acceptor.

7.35,3 Programming - Flags SR3

Alarms Enabled:

Check = ON
Uncheck = OFF

Sorter Timeout ON:

Check = ON
Uncheck = OFF

Coin Tweaks Enabled:

Check = ON
(see section [7.34 Programming - Tweak](#)
for more details)
Uncheck = OFF

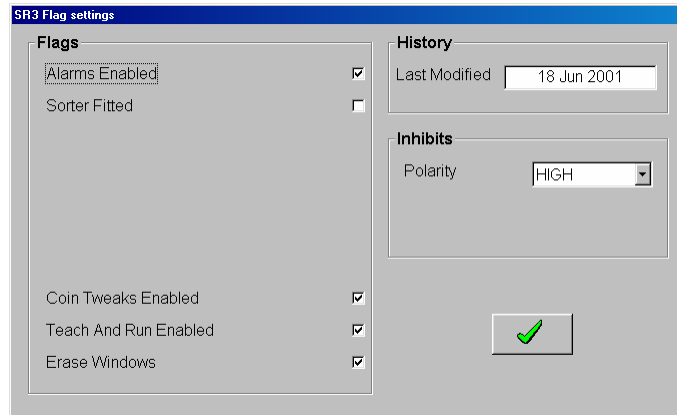

Teach and Run Enabled:

Check = ON (see section [7.33 Programming - Teach](#) for more details)
Uncheck = OFF

Erase Windows:

Check = ON (allows MechTool™ to erase all the programmed windows)
Uncheck = OFF

Note: Teach and Run™ is NOT available if MechTool™ is OFF.

Inhibits – Polarity:

DO NOT CHANGE:

Click on the GREEN tick to program the changes into the acceptor.

7.35,4 Programming - Flags Condor Plus

Alarms Enabled:

Check = ON
 Uncheck = OFF

Window Tweaking:

When the checkboxes are changed, the help text, ⇒ 11, automatically changes to show the effect of the new settings.

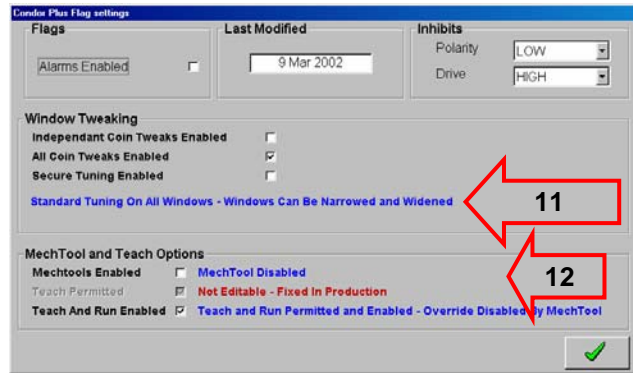

MechTool™ and Teach Options:

See on screen help text ⇒ 12.

Note: Teach and Run™ is NOT available if MechTool™ is OFF.

Inhibits:

Please refer to the Condor Plus MechTool™ manual (TSP020) for a detailed explanation.

When the GREEN tick is clicked, the following summary screen is displayed:-

The screenshot shows a summary screen titled 'Condor Plus Flag settings'. It contains a table with three columns: 'Feature', 'Current State', and 'Availability On Mech'. The table lists several features and their states. A green checkmark button is in the bottom right corner.

Feature	Current State	Availability On Mech
MechTool	Disabled	Feature Disabled
Teach Permitted	Enabled	Enabled - Not Editable
Teach and Run	Enabled	Enabled - Locked By MechTool
All Coin Tweaks	Enabled	Enabled - Locked By MechTool
Individual Coin Tweaks	Disabled	Disabled - Locked By MechTool
Secure Tuning	Disabled	Disabled - Locked By MechTool

Note: “Locked by MechTool™” indicates that the flag cannot be changed using MechTool™ because MechTool™ is OFF.

Teach and run is DISABLED!!!!

Click the GREEN tick to continue.

7.36 PROGRAMMING – SORTER

Only available for SR5 products.

For settings to be effected, the SR5 must be set to EEPROM mode.

See section [7.35.1 Programming - Flags SR5](#)

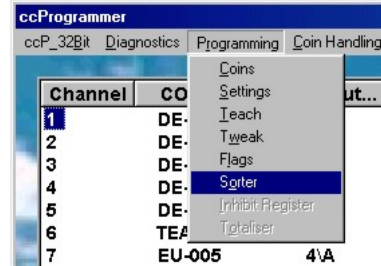

To change the sorter paths, simply click on the required path ⇒ 13 and while holding the left mouse button down, drag the sorter path to the required coin position ⇒ 14.

Please refer to the SR5 Technical Manual TSP010 for an explanation of the differences between the sorter paths.

Click on the **GREEN** tick to program the changes into the acceptor.

Click on the **RED** cross to cancel the operation.

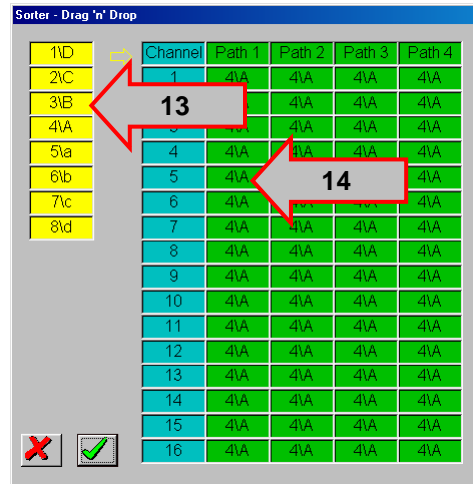

The SR5 BDTA model only has one sorter path per coin available for programming.

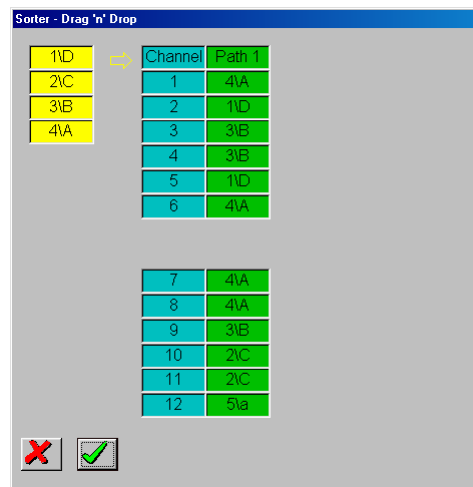

7.37 PROGRAMMING – INHIBIT REGISTER

Only available on SR3 and Condor Plus.

To enable a coin check the corresponding checkbox.

Click on the **GREEN** tick to program the changes into the acceptor.

Click on the **RED** cross to cancel the operation.

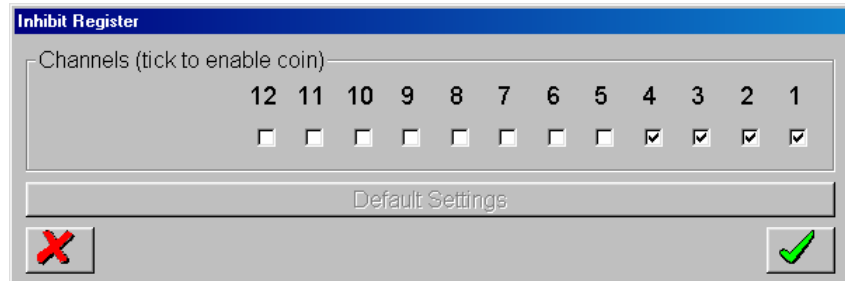
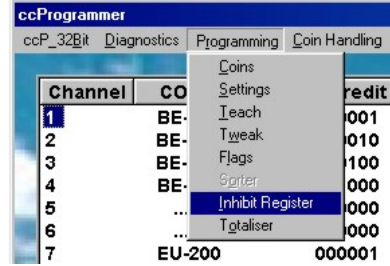

7.38 PROGRAMMING – TOTALISER

Only available on SR3 Type 2.

To save the settings click on the disk icon.



To open a previously saved file, click on the open folder icon.

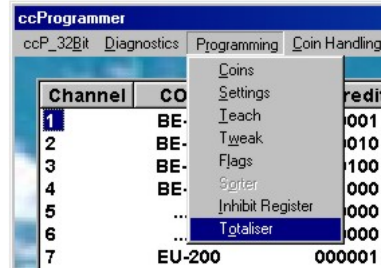

Up to 8 different totaliser settings can be programmed ⇒ 15.

Coin Values, Game Prices and Lowest Coin values can be dragged and dropped from the YELLOW boxes ⇒ 16.
[X10] ⇒ 17 multiplies the numbers above by 10.

Enter Coin Values – e.g. £1 = 100.

Enter up to 8 Game Prices – these do not have to be different.

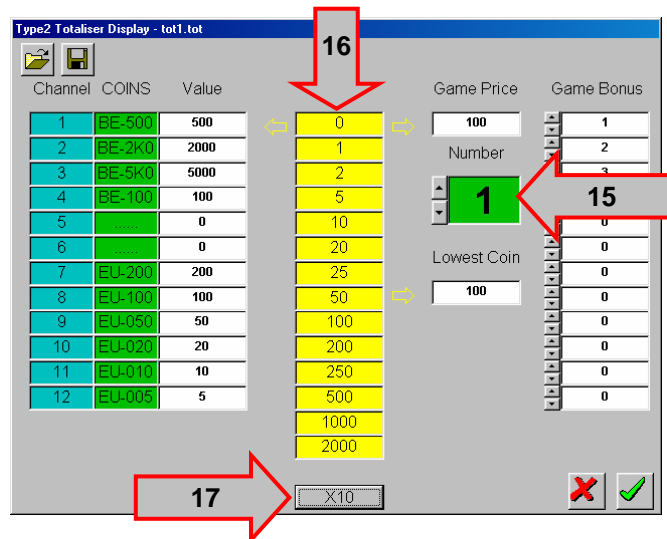

Enter Game Bonuses – for Coins1 to 12. These bonuses are for the specific coins only. Bonuses are NOT accumulated, i.e. in the above example 1 bonus is given for Coin 1 (BE-500), if 5 x Coin 4 (BE-100) are entered the bonus will NOT be awarded.

Click on the GREEN tick to program the changes into the acceptor.
 Click on the RED cross to cancel the operation.

Please refer to the SR3 Type 2 Technical Manual (TSP019) for more details on the totaliser operation.

7.4 Coin Handling



Before coin handling can be carried out, the relevant coins must be enabled. This can be achieved by either checking the corresponding coin checkbox or clicking on **[Bank 1]** to enable coins 1 to 8 or **[Bank 2]** to enable coins 9 to 16.

Once the coins have been enabled, click **[Go]** to start the test.

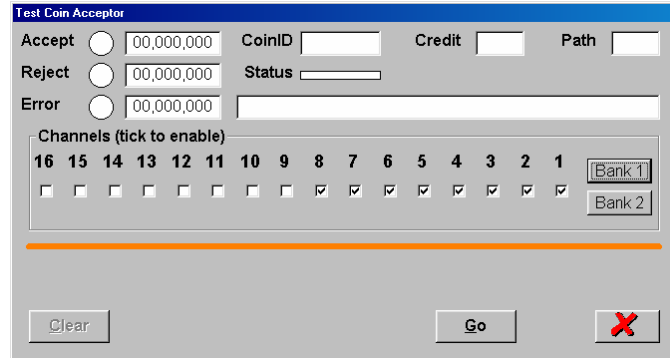

If no coins have been enabled, the following error will be displayed.



7.41 COIN HANDLING – ACCEPT

Each time a coin is accepted the 'Accept' indicator will turn **GREEN**, the 'Accept' counter will increment by 1, the 'CoinID', the **SERIAL** 'Credit' code and the first programmed coin 'Path' will all be displayed.

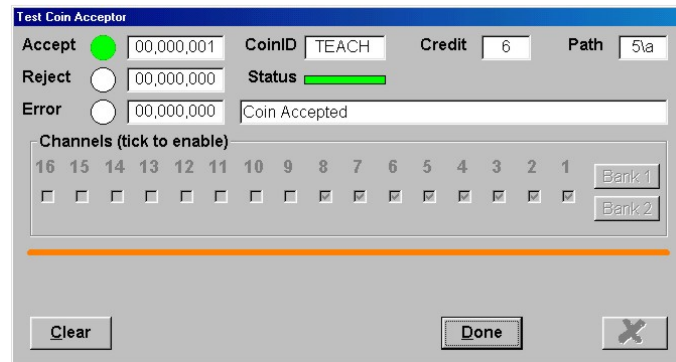

7.42 COIN HANDLING – REJECT

If a coin is not programmed or the readings fall outside the pre-programmed windows the 'Reject' indicator will turn **YELLOW**, the 'Reject' counter will increment and the 'Status' will show 'Reject coin'.

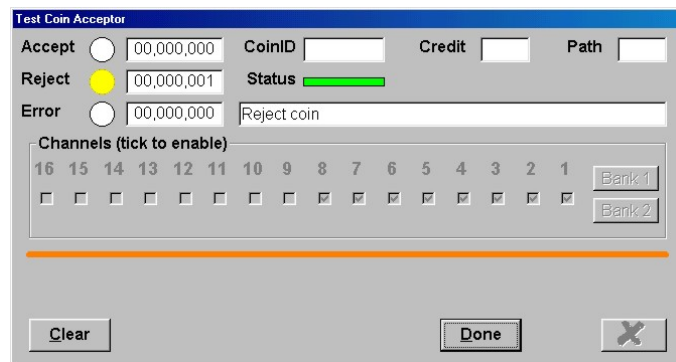

7.43 COIN HANDLING – ERROR

If the relevant coin has not been enabled, the Error counter will be incremented and the message “Inhibited coin x” will be displayed ⇒ 18.

Should any other error occur during testing, a message stating the fault will be displayed in the ‘Status’ window.

When coin handling is finished, click on the **[Done]** button, then click on the **RED** cross to return to the main screen.

[Clear] resets all the counters to zero and enables the coin ‘Channels’ for modification.

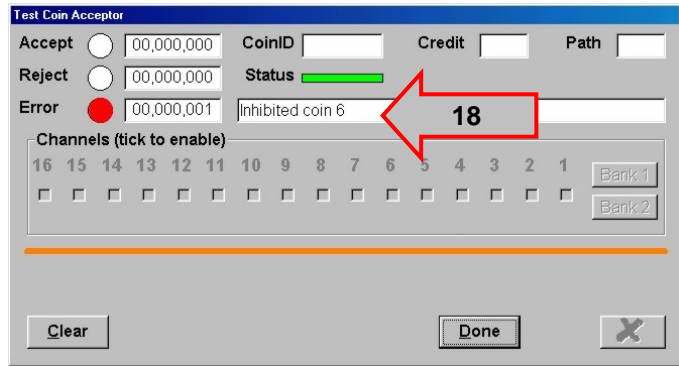

7.44 COIN HANDLING – SR3 / CONDOR PLUS

Because the SR3 and the Condor Plus only have 12 coin channels, only 12 checkboxes will be shown.

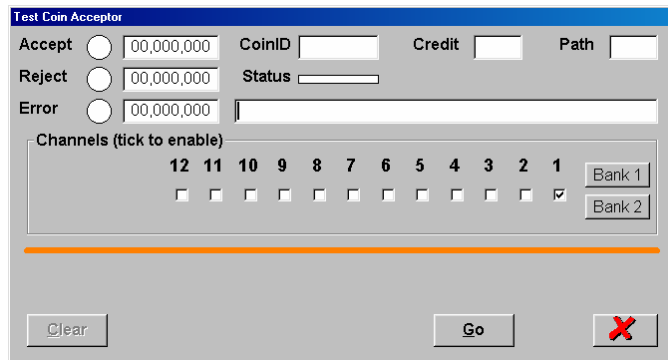

7.5 Macros

7.51 MACROS - INSTALL

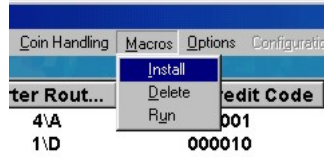

If a macro is supplied on floppy disk **[Macros] [Install]** will copy the macro to the relevant directory.

If the macro is sent by e-mail, copy the macro into the directory shown ⇒ 19.

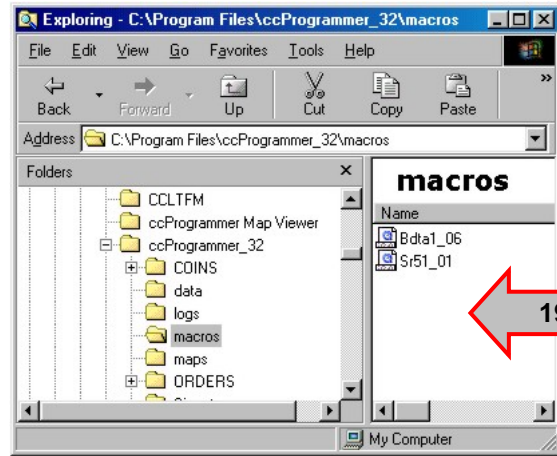

7.52 MACROS - DELETE

To delete a macro select **[Macros] [Delete]**.
Select the macro ⇒ 20 and click **[Delete]**.

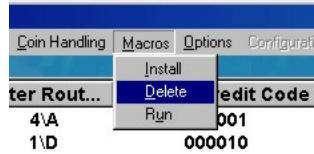

Click on the **RED** cross to exit.

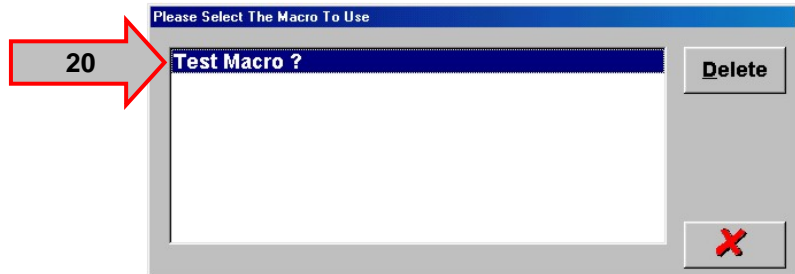

7.53 MACROS - RUN

To run a macro select **[Macros] [Run]**.
Select the macro ⇒ 21 and click **[Run]**.

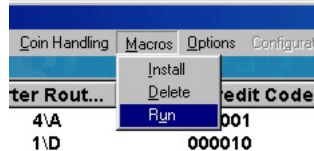

Click on the **RED** cross to exit.

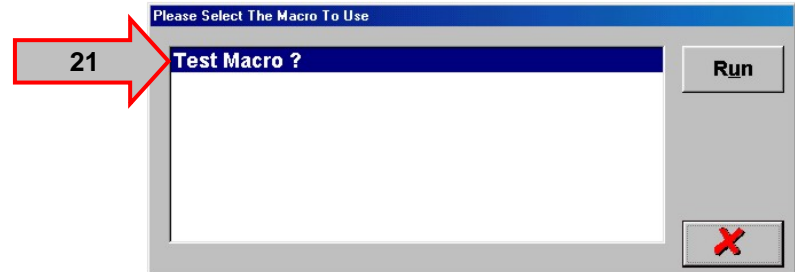

7.6 Options

7.61 OPTIONS - CHANGE PASSWORD

Change password, changes the password required to enter **ccProgrammer**.

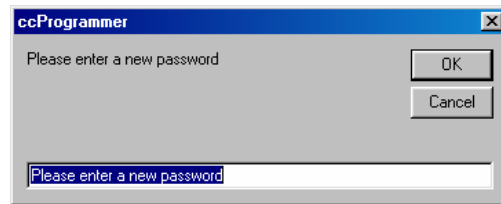
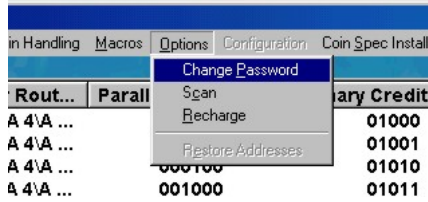

7.62 OPTIONS – SCAN

Scan returns the user to the **ccTalk** Bus Explorer screen.

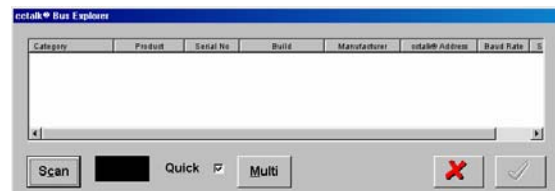
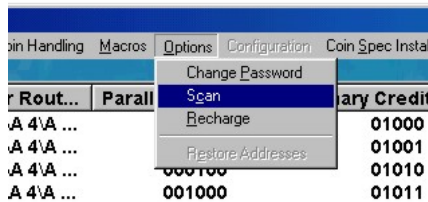

7.63 OPTIONS - RECHARGE

After a 12 month period the **ccProgrammer** will need re-charging.

Contact Money Controls Technical Services Department on +44 (0)161 955 0124 quoting the code in the display box.

Note:- This code changes every time the display box is opened, so DO NOT close this window until you have entered the new code in the box provided.
If you enter this screen by mistake the only way out is to press <Ctrl> + <Alt> + .

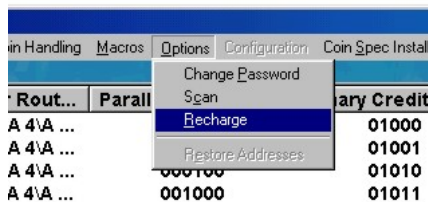

7.64 OPTIONS - RESTORE ADDRESSES

If more than one acceptor has been attached to the bus, [**Restore Addresses**] resets the acceptor address back to its original address = 2.

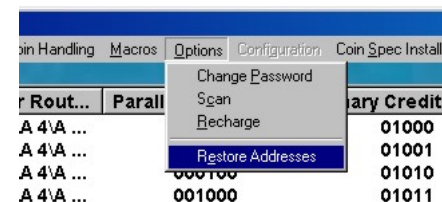

7.7 Configuration

Not available on this version of **ccProgrammer**.

7.8 Coin Spec Install

7.81 COIN SPEC INSTALL – CCPROGRAMMER

Only use this option when installing the coinspecs from the supplied CD.

If a coinspec is supplied by e-mail the coinspecs will be supplied in a self-extracting .zip file with the extension .mail. Rename the extension .exe and double click the file to unzip.

Bit Code	Binary Credit Code
1	001000
0	001001

To check the files have successfully unzipped, check the relevant directory as shown.

Each product has its own sub-directory which is then sub-divided into STD (standard) and FRT (front plate) directories.

Some directories may also contain macros which are automatically run at the time of programming, because of specific requirements by some currencies.

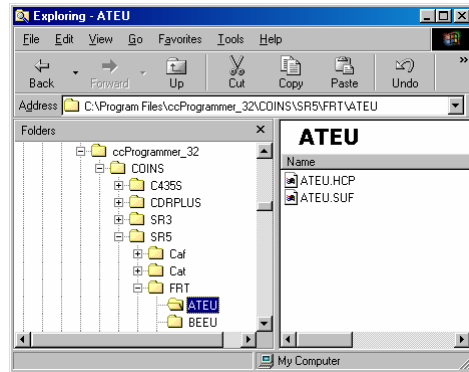

7.9 About

Shows the version of **ccProgrammer** being used.

Click on the **RED** cross to exit.

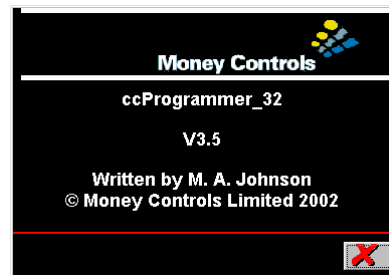

8. Programming Coins

This allows the programming of coins in specific coin locations, new credit codes and new sorter paths.

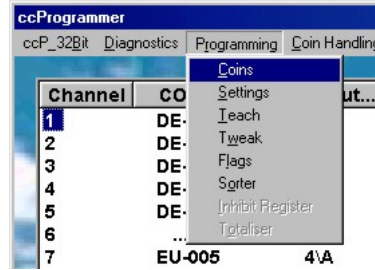

8.1 Programming Coins - SR5

When using for the first time no 'Orders' will be available.

To create an order first click the **[New]** button.

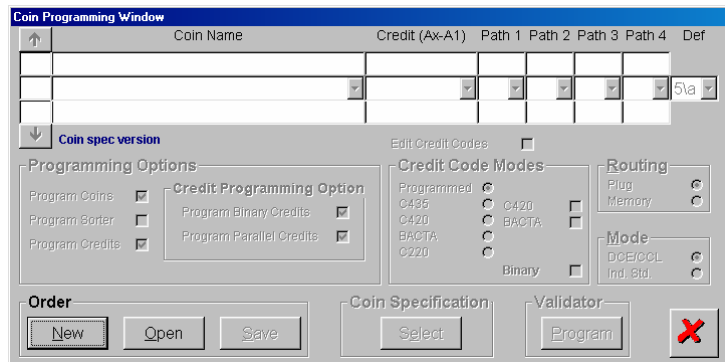

This will automatically open the correct folder. In the example the SR5\STD directory has been opened.

Double click on the country folder required.

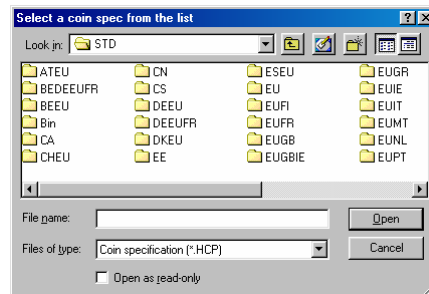

Highlight the coinspec (.HCP) file and click **[Open]**.

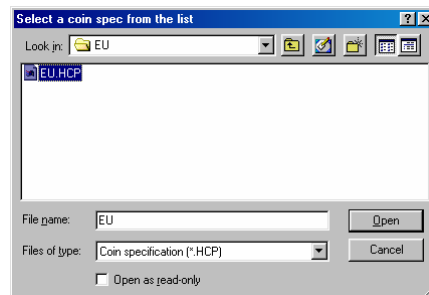

8.11 CHANGING THE COINS - SR5

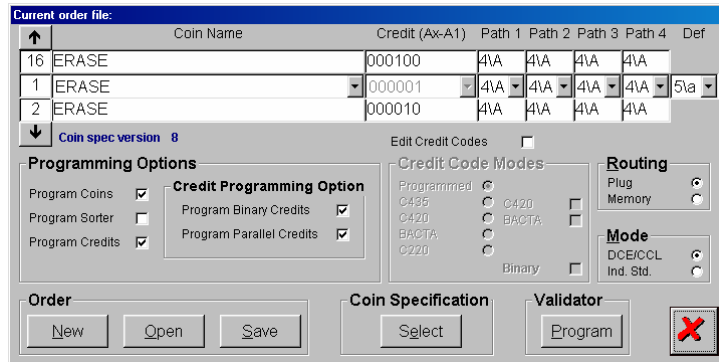

Initially all the coins are set to “ERASE”.

Click on the down arrow to show available coins.

If coins already programmed are to be saved, select the “IGNORE” coin.

There is no method to set all the coins to “IGNORE”. Each coin has to be individually selected.

Click on the coin to program.

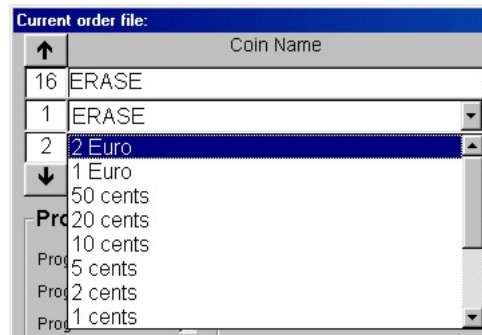

Click on the Up or Down arrow to move to the next or previous coins.

Repeat the coin selection process for the remaining coin positions.



8.12 PROGRAMMING OPTIONS - SR5

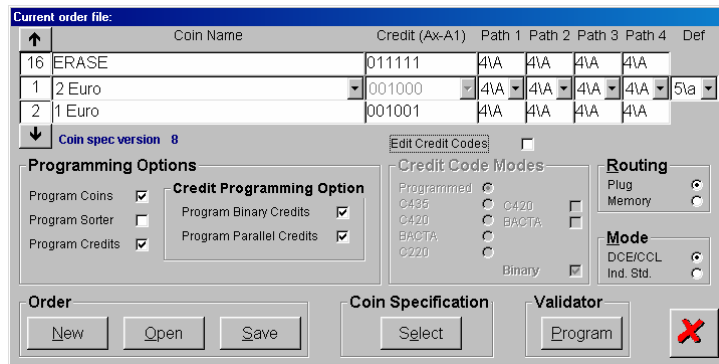

To program a new coinset, only check the **[Program Coins]** checkbox.
 To program new sorter paths, only check the **[Program Sorter]** checkbox.
 To program new credit codes, only check the **[Program Credits]** checkbox.

8.12.1 Credit Programming Option - SR5

To program new binary credits, only check the **[Program Binary Credits]** checkbox.
 To program new parallel credits, only check the **[Program Parallel Credits]** checkbox.

Note: any combination of the above programming options can be selected simultaneously.

8.13 CREDIT CODE MODES - SR5

To edit the credit codes, check the **[Edit Credit Codes]** checkbox.

- Programmed** = What is currently programmed in the acceptor
- C435** = Standard C435 credit codes.
- C420** = Standard C420 credit codes.
- BACTA** = Standard UK AWP BACTA credits.
- C220** = Standard C220 credit codes – when selected the Coin in Mech. “CIM” option is enabled.

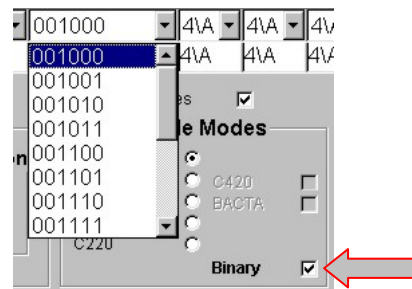
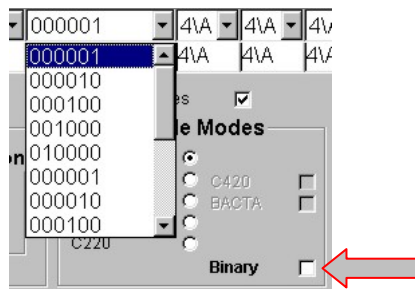
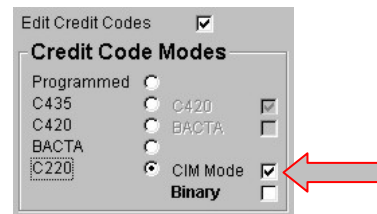

If **[Binary]** is unchecked then available parallel credit codes appear in the dropdown box.
 If **[Binary]** is checked then available binary credit codes appear in the dropdown box.

Simply highlight the new credit code to change.

8.14 ROUTING - SR5

To change the sorter paths, click on the Down arrow to reveal available sorter paths.

Click on the required sorter path to change.

Repeat, if required, for the remaining sorter paths.

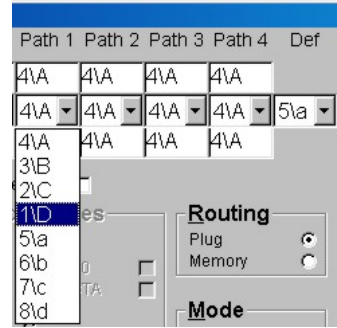

Check **[Plug]** to enable the Routing Plug.

Note: Routing Plug mode IGNORES pre-programmed sorter paths.

Check **[Memory]** to enable the pre-programmed sorter paths.

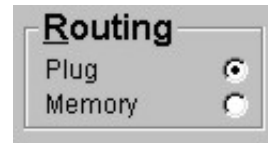

8.15 MODE

Check **[DCE/CCL]** to enable coin position 5 as a COIN.

Check **[Ind. Std]** to enable coin position 5 as a TOKEN.

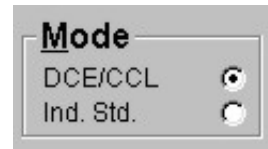

8.16 ORDER - SR5

Click **[New]** to create a new order.

Click **[Open]** to open a previously saved order.

Click **[Save]** to save the current order.

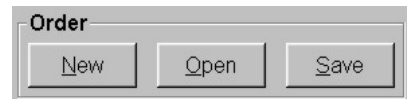

8.17 COIN SPECIFICATION - SR5

Click **[Select]** to change the current coinspec. All other settings will stay the same.



A message will appear.

Click on **[Yes]** or **[No]**.

If **[Yes]** repeat from [8.11](#).

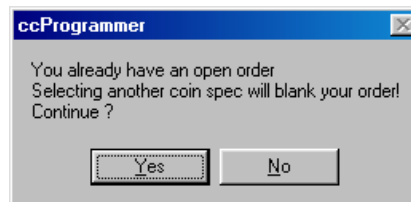

8.18 VALIDATOR - SR5

Click **[Program]** to program the current order into the acceptor.



Various messages will appear depending on what you are programming.

UNDER NO CIRCUMSTANCES REMOVE THE ACCEPTOR WHILE PROGRAMMING IS IN OPERATION.



8.19 COINSPEC VERSION - SR5

The coinspec version is located underneath the coin windows.



8.2 Programming Coins - SR3

When using for the first time no 'Orders' will be available.

To create an order first click the **[New]** button.

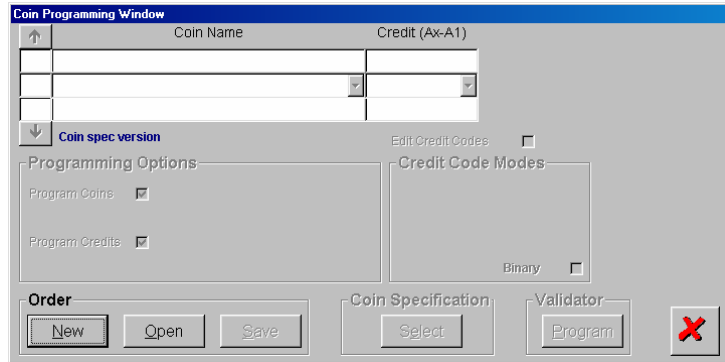

This will automatically open the correct folder. In the example the SR3\STD directory has been opened.

Double click on the country folder required.

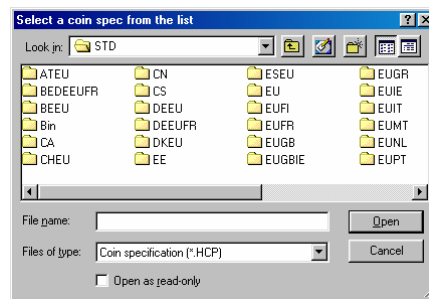

Highlight the coinspec (.HCP) file and click **[Open]**.

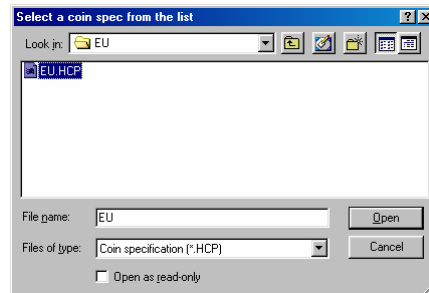

8.21 CHANGING THE COINS - SR3

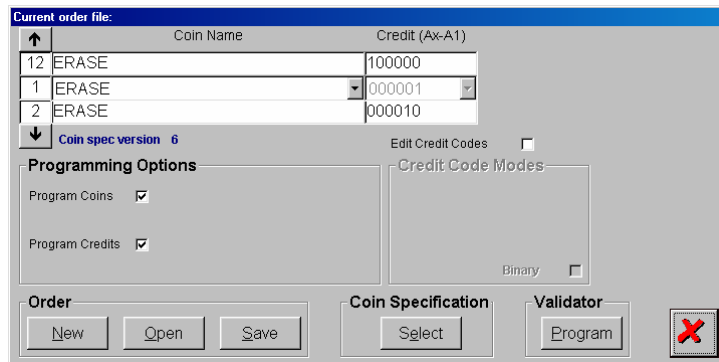

Initially all the coins are set to “ERASE”.

Click on the down arrow to show available coins.

If coins already programmed are to be saved, select the “IGNORE” coin.

There is no method to set all the coins to “IGNORE”. Each coin has to be individually selected.

Click on the coin to program.



Click on the Up or Down arrow to move to the next or previous coins.

Repeat the coin selection process for the remaining coin positions.



8.22 PROGRAMMING OPTIONS - SR3

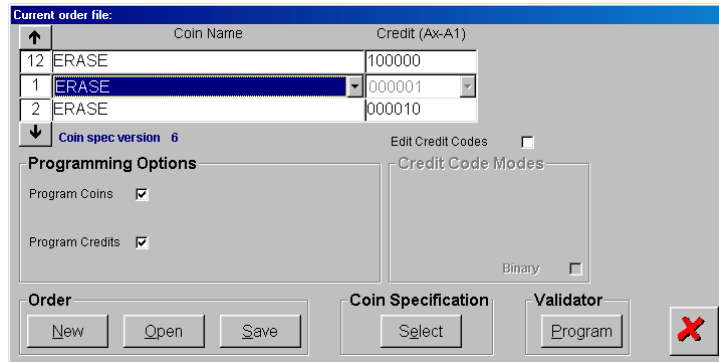

To program a new coinset, only check the **[Program Coins]** checkbox.
To program new credit codes, only check the **[Program Credits]** checkbox.

Note: any combination of the above programming options can be selected simultaneously.

8.23 CREDIT CODE MODES - SR3

To edit the credit codes, check the **[Edit Credit Codes]** checkbox.

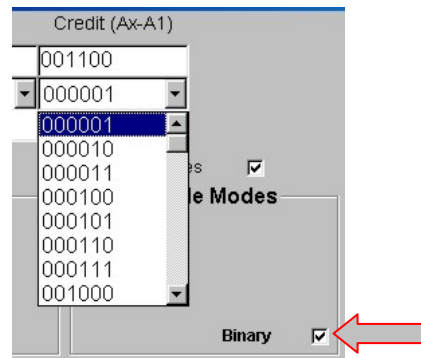
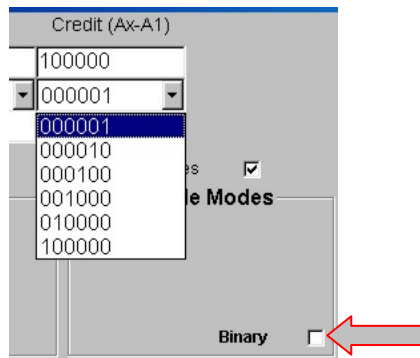
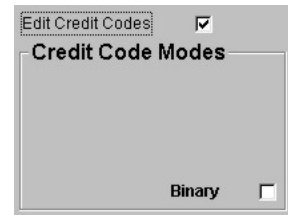

If **[Binary]** is unchecked then available parallel credit codes appear in the dropdown box.
If **[Binary]** is checked then available binary credit codes appear in the dropdown box.

Simply highlight the new credit code to change.

8.24 ORDER - SR3

Click **[New]** to create a new order.
 Click **[Open]** to open a previously saved order.
 Click **[Save]** to save the current order.

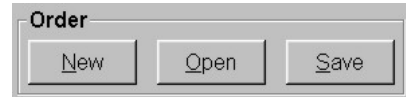

8.25 COIN SPECIFICATION - SR3

Click **[Select]** to change the current coinspec.
 All other settings will stay the same.



A message will appear.
 Click on **[Yes]** or **[No]**.

If **[Yes]** repeat from [8.21](#)

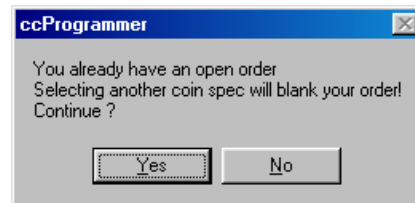

8.26 VALIDATOR - SR3

Click **[Program]** to program the current order into the acceptor.

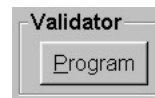

Various messages will appear depending on what you are programming.

UNDER NO CIRCUMSTANCES REMOVE THE ACCEPTOR WHILE PROGRAMMING IS IN OPERATION.

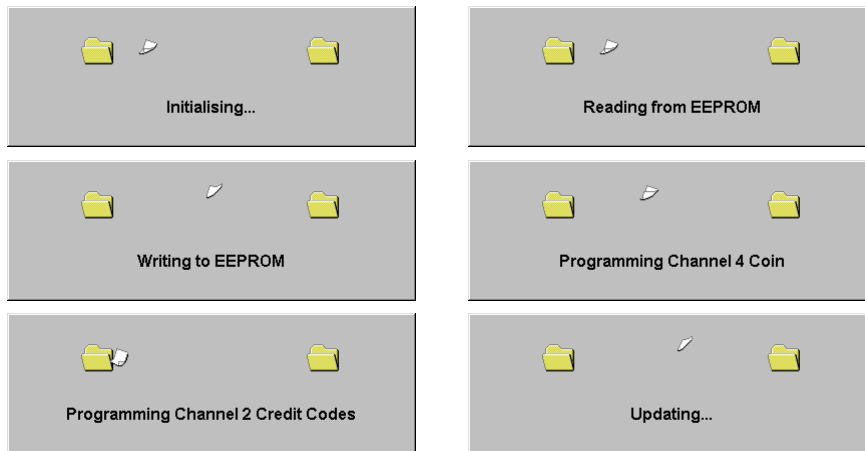

8.27 COINSPEC VERSION - SR3

The coinspec version is located underneath the coin windows.



8.3 Programming Coins - Condor Plus

When using for the first time no 'Orders' will be available.

To create an order first click the **[New]** button.

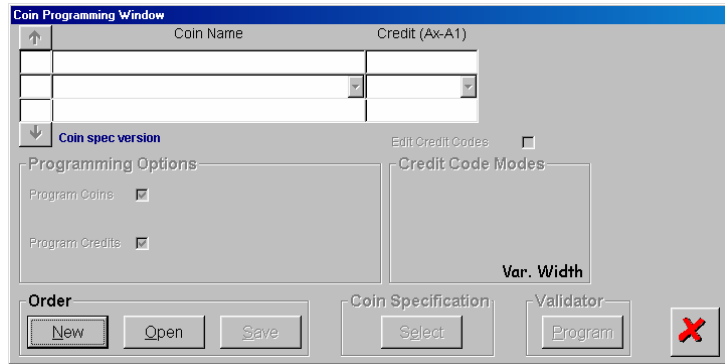

This will automatically open the correct folder.
In the example the CDRPLUS\STD directory has been opened.

Double click on the country folder required.

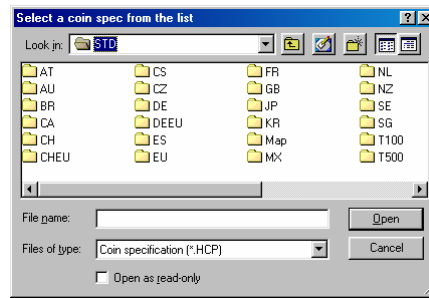

Highlight the coinspec (.HCP) file and click **[Open]**.

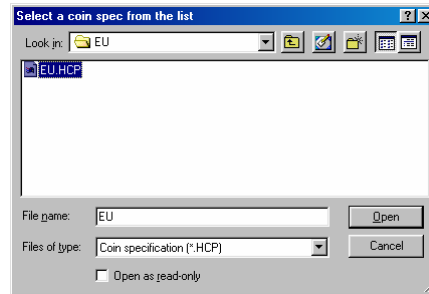

8.31 CHANGING THE COINS - CONDOR PLUS

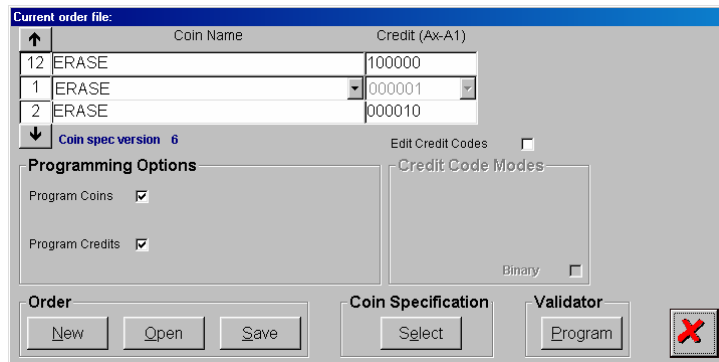

Initially all the coins are set to “ERASE”.

Click on the down arrow to show available coins.

If coins already programmed are to be saved, select the “IGNORE” coin.

There is no method to set all the coins to “IGNORE”. Each coin has to be individually selected.

Click on the coin to program.

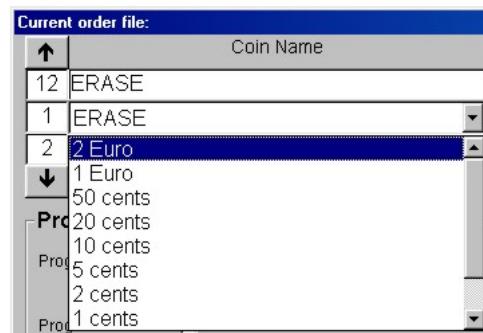

Click on the Up or Down arrow to move to the next or previous coins.

Repeat the coin selection process for the remaining coin positions.



8.32 PROGRAMMING OPTIONS - CONDOR PLUS

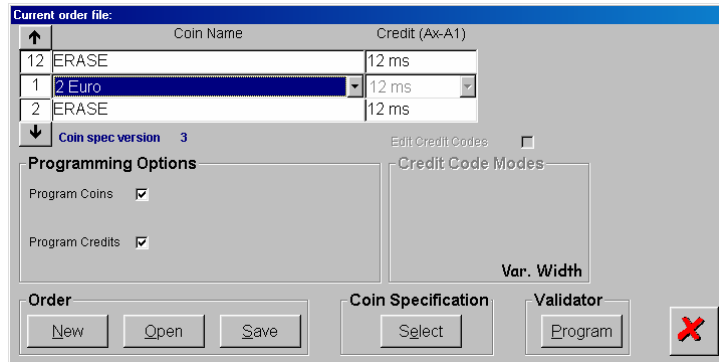

To program a new coinset, only check the **[Program Coins]** checkbox.
 To program new credit codes, only check the **[Program Credits]** checkbox.

Note: any combination of the above programming options can be selected simultaneously.

8.33 CREDIT CODE MODES - CONDOR PLUS

If the Condor Plus is a single credit version
 “Var. Width” will be displayed and the credit
 codes are NOT editable.

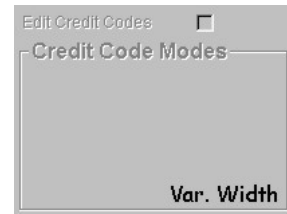

If the Condor Plus is a Multi-Pulse version
 “Pulsed” will be displayed and the credit
 pulses can be changed by checking the
[Edit Credit Codes] checkbox.

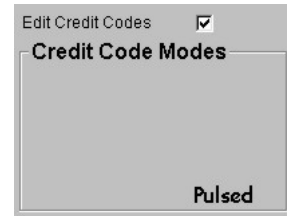

Simply highlight the new number of pulses
 to change.

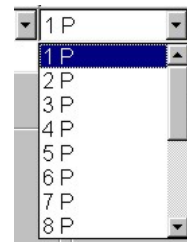

8.34 ORDER - CONDOR PLUS

Click **[New]** to create a new order.
 Click **[Open]** to open a previously saved order.
 Click **[Save]** to save the current order.

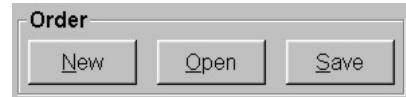

8.35 COIN SPECIFICATION - CONDOR PLUS

Click **[Select]** to change the current coinspec.
 All other settings will stay the same.



A message will appear.
 Click on **[Yes]** or **[No]**.

If **[Yes]** repeat from [8.11](#).

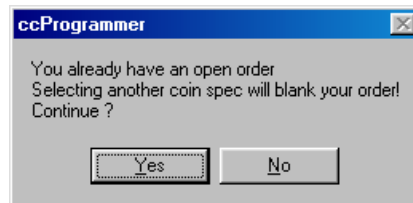

8.36 VALIDATOR - CONDOR PLUS

Click **[Program]** to program the current order into the acceptor.

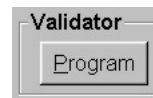

Various messages will appear depending on what you are programming.

UNDER NO CIRCUMSTANCES REMOVE THE ACCEPTOR WHILE PROGRAMMING IS IN OPERATION.

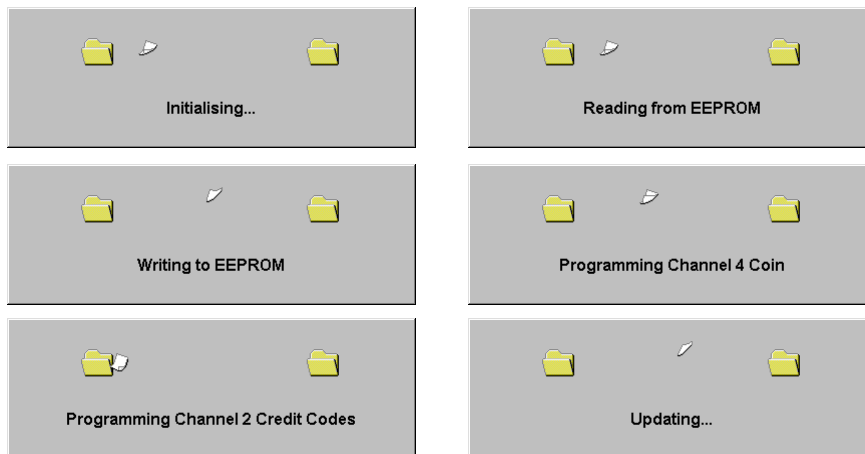

8.37 COINSPEC VERSION - CONDOR PLUS

The coinspec version is located underneath the coin windows.



This manual is intended only to assist the reader in the use of this product and therefore Money Controls shall not be liable for any loss or damage whatsoever arising from the use of any information or particulars in, or any incorrect use of the product. Money Controls reserve the right to change product specifications on any item without prior notice